

CREATE A TRIANGLE (2D)

YOU NEED

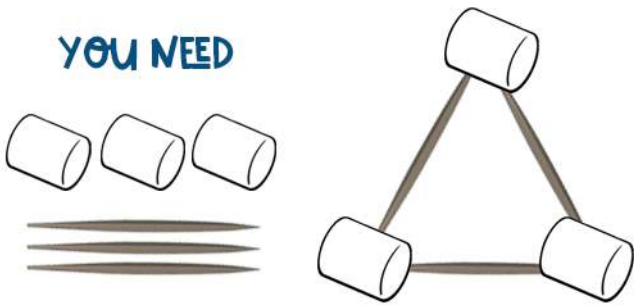

CREATE A PYRAMID (3D)

YOU NEED

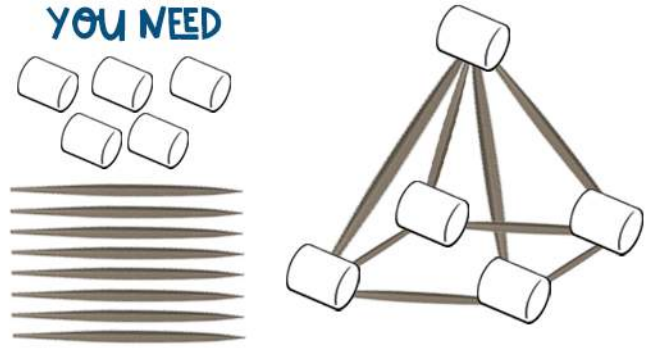

CREATE A SQUARE (2D)

YOU NEED

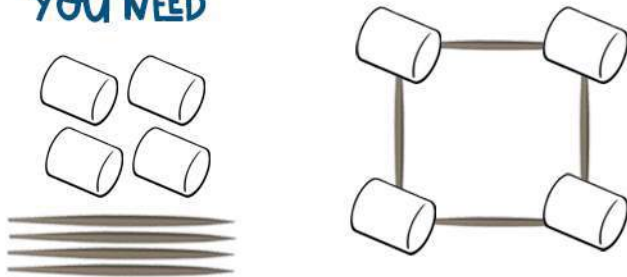

CREATE A CUBE (3D)

YOU NEED

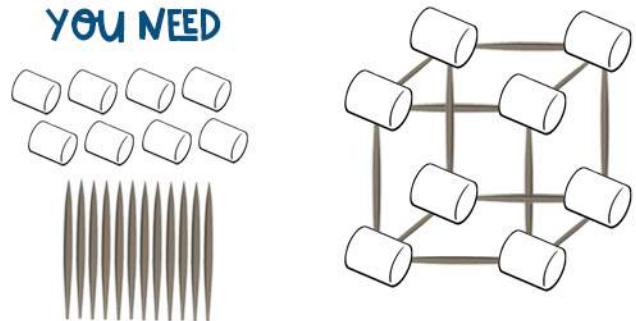

CREATE A PENTAGON (2D)

YOU NEED

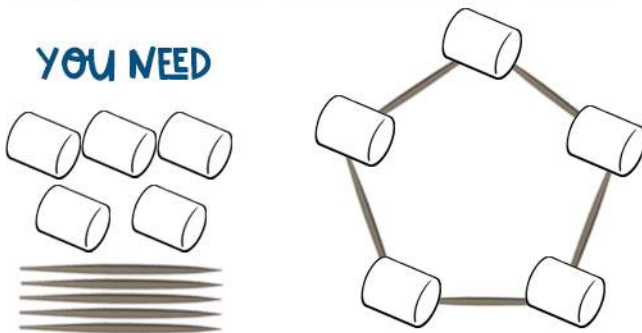

CREATE A PENTAGONAL PRISM (3D)

YOU NEED

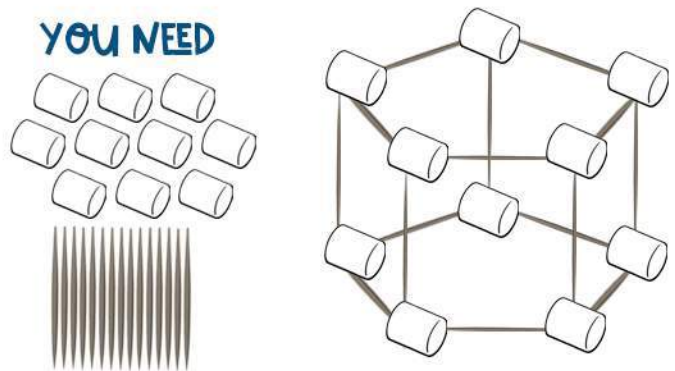

CREATE A RECTANGLE (2D)

YOU NEED

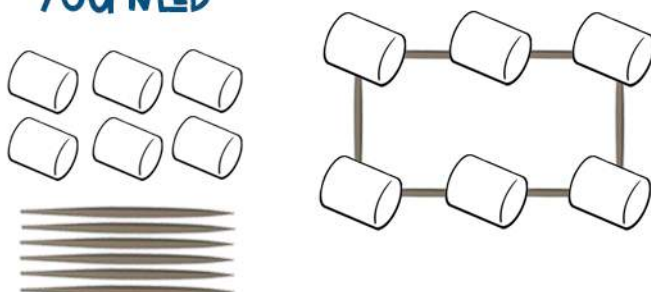

CREATE A RECTANGULAR PRISM (3D)

YOU NEED

